

POWER RATING

Production tolerance : ± 3%

MODEL	CONDITIONS	POWER	rpm	Base Engine
4V222TIH	HEAVY DUTY	588kW (800PS)	1,800	D2842LB
4V222TIM	MEDIUM DUTY	647kW (880PS)	2,100	
4V222TIL	LIGHT DUTY	883kW (1,200PS)	2,300	

Note : 1) No reduction in rating for intake air temperature is up to 45 °C (318K) and sea water temperature is up to 32 °C (305K) , relative humidity is up to 60 % all data are based on operation to ISO 3046.

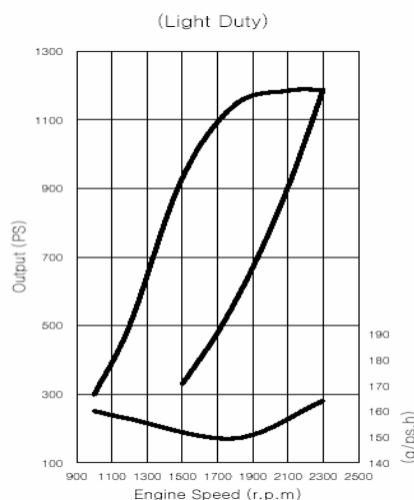
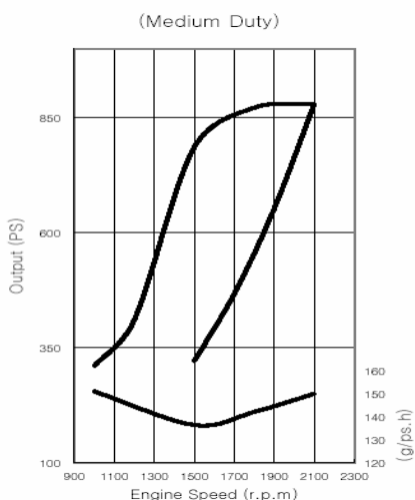
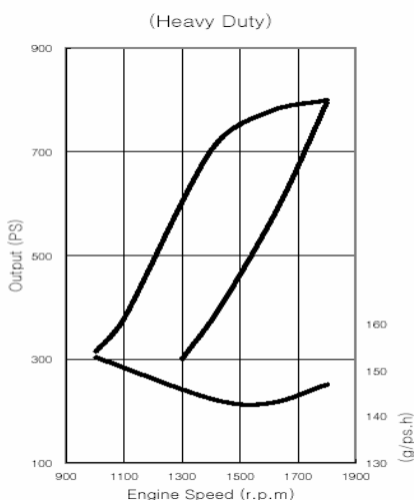
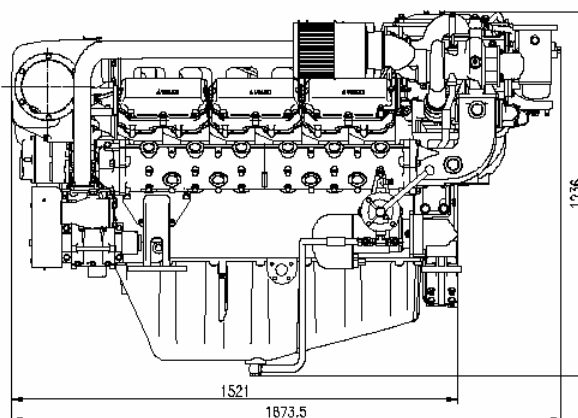
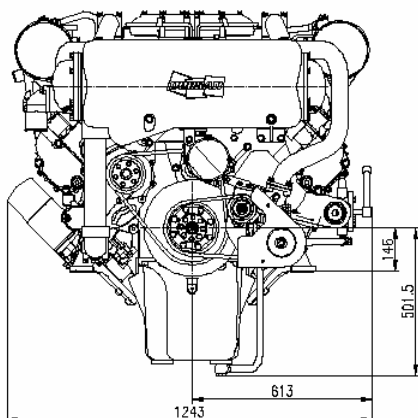

- **Heavy Duty** : Operation hours are unlimited per year, at average load is up to 90 % , at full load is up to 80 %
Typical gearbox ratio: 2.5 ~ 6
(Fishing trawler, Tug boat, Pushing vessel, Cargo boat, Freighter, Ferry)
- **Medium Duty** : Operation hours are up to 3,000 per year, at average load is up to 70 %
At full load is (up to 30 % / 4hrs per 12 hour operation period)
Typical gearbox ratio: 2 ~ 3.5
(Fishing boat, Pilot boat, Escort boat, Passenger boat, Ferry, Cruising vessel)
- **Light Duty** : Operation hours are up to 1,000 per year, at average load is up to 50 %
At full load is (up to 20 % / 2hrs per 12 hour operation period)
Typical gearbox ratio: 1 ~ 2.5
(Light weight fishing boat, Yacht, Coastguard boat, Fast boat, Fire pump, Navy)

Engine Specification					
Model	Units	4V222TIH	4V222TIM	4V222TIL	
Engine type		4 valve, 4 cycle, V type, direct- injection, water cooled with wet turbo charger & inter-cooler			
Rating output (B.H.P)	kW (PS)/rpm	588(800)/1,800	647(880)/2,100	883(1,200)/2,300	
Displacement	cc	21,927			
Cylinder number - bore(φ) x stroke	mm	12 - φ128 x 142			
Valve clearance at cold	In / Ex	mm 0.4 / 0.5			
Low idling rpm	rpm	725 ± 25			
No load max. rpm	rpm	below 2,070	below 2,415	below 2,645	
Mean effective pressure	kg/cm ²	18.2	17.2	21.4	
Mean piston speed	m/sec.	8.52	9.94	10.89	
Compression ratio		14.3 : 1	14.3:1	14.3:1	
Firing order		1 - 12 - 5 - 8 - 3 - 10 - 6 - 7 - 2 - 11 - 4 - 9			
Governor type of injection pump		Mechanical variable speed (R.Q.V)			
Fuel consumption	g / PS.h	147	150	164	
	Lit / h	143	160	239	
Starting system		Electric Starting by starter motor			
Starter motor capacity	V - kW	24 - 6.6			
Alternator capacity	V - A	24 - 50			
Battery	V - Ah	24 - 200			
Cooling system		Indirect sea water cooling with heat exchanger			
Cooling water capacity	Max. / Min.	lit. 103 / 92			
Fresh water pump type		Centrifugal type, driven by belt			
Sea water pump type		Bronze impeller type driven by belt			
Lubricating oil (Engine)	pan capacity	lit. Max : 40, Min : 33 (Engine total : 43)			
	pressure	kg/cm ² Full : 3.5, Idle : 1.2			
Direction of revolution	crankshaft	Counter clockwise viewed from stern side			
Engine Size (L x W x H)	mm	1,521 x 1,243 x 1,236			
Engine dry weight	kg	1,920	1,920	1,920	

psi = kg/cm² x 14.22
 lb/ft. = N.m x 0.737
 kW = 0.2388 kcal/s

lb = kg x 2.205
 lb/PS.h = g/kW.h x 0.00162
 cfm = m³/min x 35.3

hp = PS x 0.98635
 U.S gal. = liter x 0.264



Head office
 7-11, Hwasu-Dong, Dong-Gu, Incheon, Korea
TEL : 82-32-760-1951, 1953 FAX : 82-32-761-2759
Seoul Office
 Doosan Infracore Co. Ltd.,
 22nd Floor, Doosan Tower, 18-12, Euljiro 6-ga, Jung-gu,
 Seoul, Korea.
TEL : 82-2-3398-8521-8536 FAX : 82-2-3398-8509
Web site : www.doosaninfracore.com

Specifications are subject to change without prior notice.