



Marine Diesel Engine

L136T

Daewoo Heavy Industries has made a fresh start as **Doosan Infracore**.

- *Compact Design*
- *Excellent Performance*
- *Super Low Fuel Consumption*
- *Easy Maintenance*



- Continuous Rating (BHP)
· 177kW (240PS)
- Displacement
· 8,071cc
- Dimension (L×W×H)
· 1,182×766×925mm
· Without Reduction Gear



Infracore

Engine Dimension

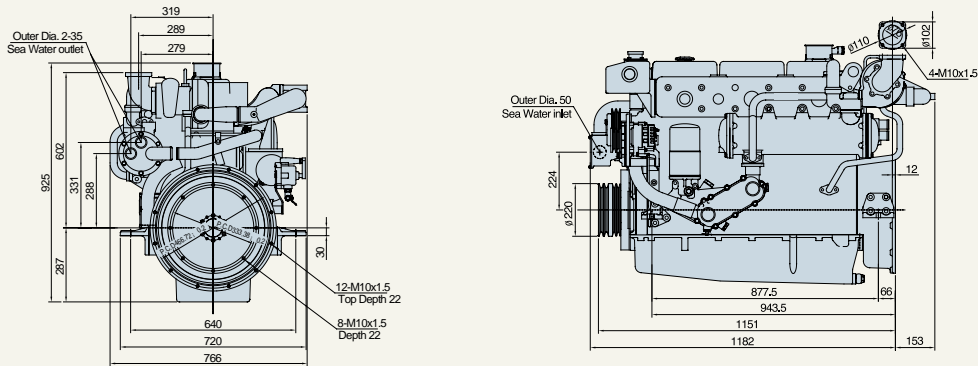

Main Specification

Model		Units	L136T	L136TL
Engine type			4cycle, In line, direct-injection, watercooled, with turbo charger	
Rating output (B.H.P)		kW(PS)/rpm	147(200) / 2,200	177(240) / 2500
Displacement		cc	8,071	
Cylinder number - bore (φ) × stroke		mm	6 - φ 111 × 139	
Valve clearance at cold		In / Ex	0.3 / 0.3	
Low idling rpm		rpm	725 ± 25	
No load max. rpm		rpm	below 2,400	below 2,750
Mean effective pressure		kg / cm ²	10.14	10.71
Mean piston speed		m / sec.	10.19	11.58
Compression ratio			16.7 : 1	
Firing order			1 - 5 - 3 - 6 - 4 - 2	
Compression pressure		At 200rpm	kg / cm ² 28 (Initial condition)	
Governor type of injection pump			Mechanical all speed (R.S.V)	
Fuel consumption		g / PS.h	155	167
		Lit/h	37	48
Injection timing(B.T.D.C)		deg	18° ± 1°	
Fuel inj. nozzle opening pressure		kg / cm ²	214+8	
Starting system			Electric Starting by starter motor	
Starter motor capacity		V - kW	24 - 4.5	
Alternator capacity		V - A	24 - 50	
Battery		V - Ah	24 - 120	
Cooling system			Indirect sea water cooling with heat exchanger	
Cooling water capacity		Max. / Min.	lit 27 / 25	
Fresh water pump type			Centrifugal type, driven by V-belt	
Sea water pump type			Rubber impeller type driven by V-belt	
Lubricating oil (Engine)		Pan capacity	lit Max : 23, Min : 17 (Engine total : 25)	
		Pressure	kg / cm ² Full : 3.5, Idle : 1.2	
Marine gear		Gear ratio	1.61 2.06 2.45 2.82 3.12 3.46	
Direction of revolution		Crankshaft	Counter clockwise viewed from stern side	
		Propeller	Clockwise viewed from stern side	
Engine Size (L×W×H)		Without M/G	mm 1,182×766×925	
		With M.gear	mm 1,541×766×963	
Engine dry weight		Without M/G	kg 745	
		With M.gear	kg 935	

Performance Curve

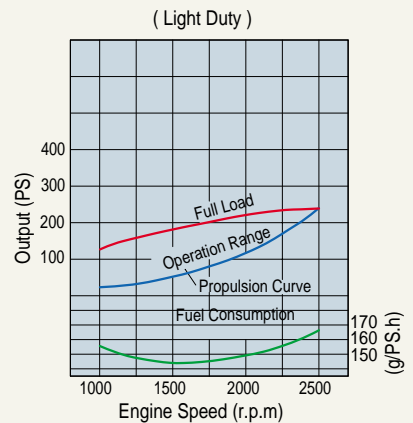
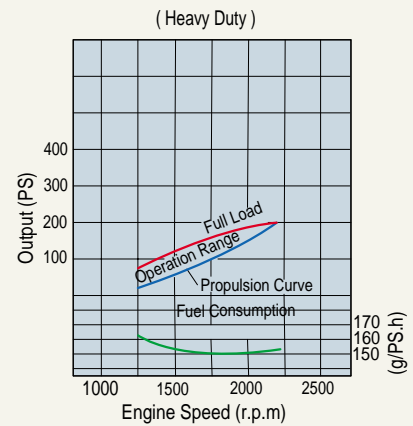

L136T(July/05)



Infracore

Seoul Office : Overseas Marketing & Sales
 Engine & Material BG
 Doosan Infracore Co., Ltd.
 22nd Floor, Doosan Tower, 18-12, Euljiro 6-ga,
 Jung-gu, Seoul, Korea.
 Tel : +82-2-3398-8534
 Fax : +82-2-3398-8509

Web site : <http://iv.doosaninfracore.com>

AUTHORIZED DEALER

* Specifications are subject to change without prior notice.