

◎ Production tolerance : ±3%

Intermittent rating kW(PS) / rpm	Max. torque N.m(kg.m) / rpm	Fuel consumption g/kW.h(g/PS.h) / rpm
85 (116) / 2,800	353 (36) / 1,600	245 (180) / 2,800

Note : -. The engine performance corresponds to ISO 3046.

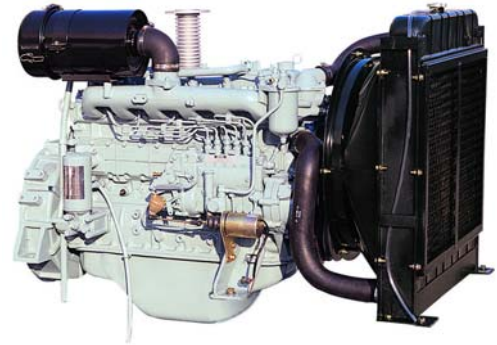

◎ MECHANICAL SYSTEM

- Engine Model PU066
- Engine Type In-line 4 cycle, water cooled
 Naturally aspirated
- Combustion type Direct injection
- Cylinder Type Replaceable dry liner
- Number of cylinders 6
- Bore x stroke 102(4.02) x 118(4.65) mm(in.)
- Displacement 5.785(353) lit.(in3)
- Compression ratio 17.5 : 1
- Firing order 1-5-3-6-2-4
- Injection timing 16° BTDC
- Compression pressure Above 28 kg/cm²(398 psi) at 200rpm
- Dry weight Approx. 450 kg (992 lb)
- Dimension 1,155 x 705 x 774.5 mm
(LxWxH) (45.5 x 27.8 x 30.5 in.)
- Rotation Counter clockwise viewed from Flywheel

◎ MECHANISM

- Type Over head valve
- Number of valve Intake 1, exhaust 1 per cylinder
- Valve lashes at cold Intake 0.40 mm(0.0157 in.)
 Exhaust 0.40 mm(0.0157 in.)

◎ VALVE TIMING

- | | Opening | Close |
|-----------------|--------------|--------------|
| ○ Intake valve | 28 deg. BTDC | 62 deg. ABDC |
| ○ Exhaust valve | 70 deg. BBDC | 28 deg. ATDC |

◎ OPTION & ACCESSORY PARTS

- Engine parts Fly wheel & housing
 Intake & exhaust manifold
- Accessory parts Raditor, silencer & air cleaner
- Electrical parts Gauge panel & stop solenoid

◎ FUEL SYSTEM

- Injection pump Zexel in-line "A" type
- Governor RSV type(all speed control)
- Feed pump Mechanical type
- Injection nozzle Multi hole type
- Opening pressure 220 kg/cm² (3,129 psi)
- Fuel filter Full flow, cartridge type
- Used fuel Diesel fuel oil

◎ LUBRICATION SYSTEM

- Lub. Method Fully forced pressure feed type
- Oil pump Gear type driven by crankshaft
- Oil filter Full flow, cartridge type
- Oil pan capacity High level 13 liters(3.432 gal.)
 Low level 10 liters(2.64 gal.)
- Angularity limit Front down 25 deg.
 Front up 25 deg.
 Side to side 25 deg.
- Lub. Oil Refer to Operation Manual

◎ PERFORMANCE CURVE

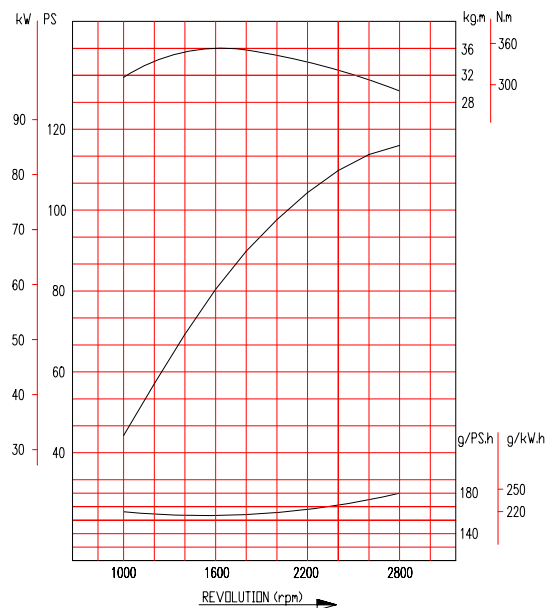

◎ COOLING SYSTEM

- Cooling method Fresh water forced circulation
- Water capacity 12 liters(3.17 gal.)
(engine only)
- Pressure system Max. 0.9 kg/cm² (12.8 psi)
- Water pump Centrifugal type driven by belt
- Water pump Capacity 220 liters (58.1 gal.)/min
at 2,800 rpm (engine)
- Thermostat Wax – pellet type
Opening temp. 71°C
Full open temp. 85°C
- Cooling fan Blower type, steel
520 mm diameter, 6 blade

◎ ELECTRICAL SYSTEM

- Charging generator 24V x 45A [or 12V x 26A] alternator
- Voltage regulator Built-in type IC regulator
- Starting motor 24V x 4.5kW [or 12V x 2.5kW]
- Battery Voltage 24V [or 12V]
- Battery Capacity 100 AH [or 150 AH](recommended)
- Starting aid (Option) Block heater

◎ ENGINEERING DATA

- Water flow 220 liters/min @2,800 rpm
- Heat rejection to coolant 14.9 kcal/sec @2,800 rpm
- Air flow 6.9 m³/min @2,800 rpm
- Exhaust gas flow 18.6 m³/min @2,800 rpm
- Exhaust gas temp. 570 °C @2,800 rpm
- Max. permissible restrictions
 - Intake system 220 mmH₂O initial
635 mmH₂O final
 - Exhaust system 1,000 mmH₂O max.

◆ CONVERSION TABLE

- | | |
|-----------------------------------|------------------------------------|
| in. = mm x 0.0394 | lb/ft = N.m x 0.737 |
| PS = kW x 1.3596 | U.S. gal = lit. x 0.264 |
| psi = kg/cm ² x 14.223 | kW = 0.2388 kcal/s |
| in ³ = lit. x 61.02 | lb/PS.h = g/kW.h x 0.00162 |
| hp = PS x 0.98635 | cfm = m ³ /min x 35.336 |
| lb = kg x 2.20462 | |

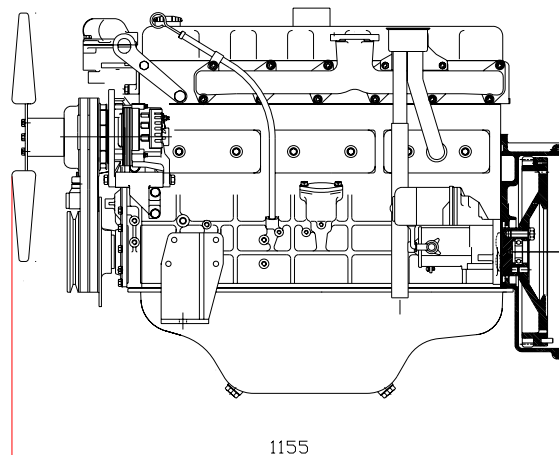
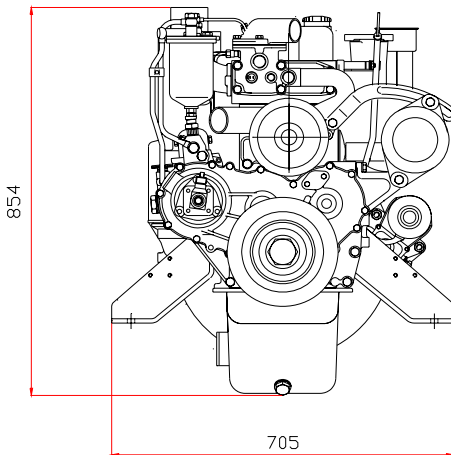

Head office

7-11, Hwasu-Dong, Dong-Gu, Incheon, Korea
TEL : 82-32-760-1437, 1964 FAX : 82-32-760-1964

Seoul Office

Doosan Infracore Co. Ltd.,
 22nd Floor, Doosan Tower, 18-12, Euljiro 6-ga, Jung-gu,
 Seoul, Korea.

TEL : 82-2-3398-8521~8535 FAX : 82-2-3398-8509

Web site : www.doosaninfracore.com

※ Specifications are subject to change without prior notice